

# LESLIE TOWNSHIP

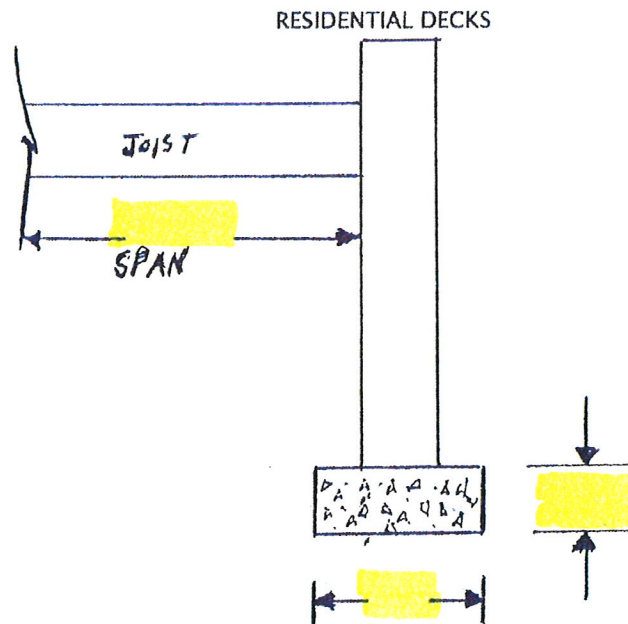

## RESIDENTIAL DECK REQUIREMENTS

Submit a drawing of proposed deck with  $\frac{1}{4}'' = 1''$  scale as well as the following:

- 1) Joist size & joist spacing
- 2) Pole size & Spacing

Footing width - 12" minimum

Footing depth - 42" minimum

Post hole size: 4 x 4 has to be a minimum of 12" diameter

4 x 6 has to be a minimum of 16" diameter

Height of deck: If 30" off ground or more, railing is required and railing height is 36" minimum

Stairs: 4 risers or more require handrail and risers must have riser boards

All fasteners must be hot dipped galvanized or stainless steel for treated lumber

Deck ledger: **size & attachments must be per R507 code**

Attached decks: flashing required per R703.8 code & figure 507.2.1(2).

Organic material (sod, topsoil, etc.) under the deck must be removed

Inspections: Call building inspector when ready for the following:

1<sup>st</sup> inspection - must be done prior to concrete placement

2<sup>nd</sup> inspection - final inspection

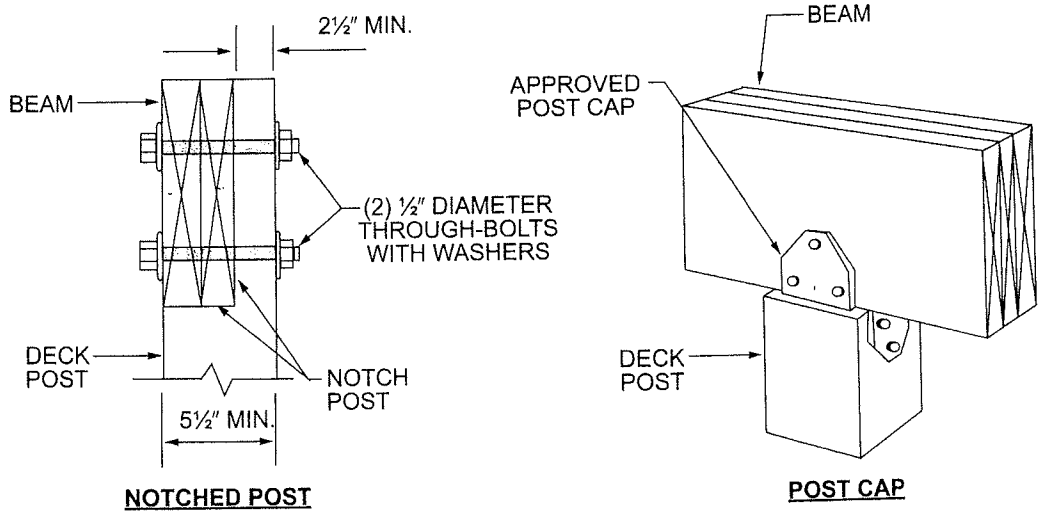

For SI: 1 inch = 25.4 mm.

**FIGURE R507.7.1  
DECK BEAM TO DECK POST**

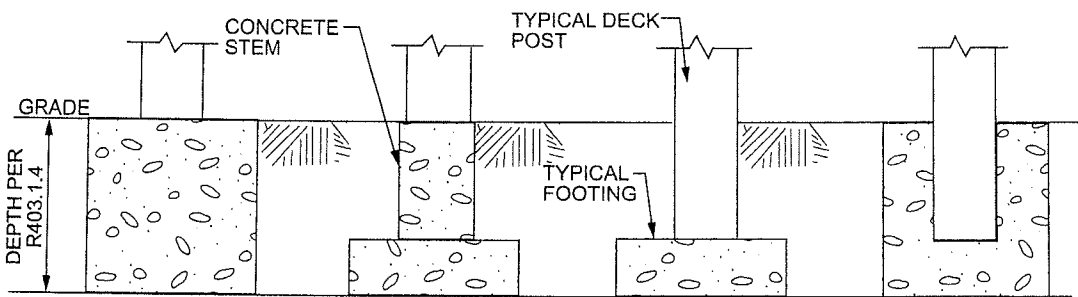

**FIGURE R507.8.1  
TYPICAL DECK POSTS TO DECK FOOTINGS**